

TWIN CLASSIFIER



Twin classifiers from Läckeby Products are designed to separate both settled and floating particles from water. The robust design underpins high reliability and a long technical service life, while maintenance requirements are minimal.

Function

The flow is directed into the machine via the top-mounted inlet and slowed down by the back wall of the tank. During the period of flow through the machine, the solid material settles and the floating material rises to the surface. The screen-fitted outlet is located in the narrow section of the tank. Floating material is captured in the outlet's screening plate and transported out via a shaftless spiral. The screening plate is continuously cleaned by a brush on the lower part of the spiral. For maximum dewatering, the settled material is transported out by a shaftless pulling spiral.

Technical features

- Robust and compact design
- Simple installation
- Shaftless screw conveyor for outfeed of dewatered material
- Without bearing at the bottom end of the conveyors
- Large sedimentation tank

Process benefits

- Separates both sedimentary and floating particles
- Screens outgoing liquid
- Maximises dewatering
- Minimises maintenance
- Reduces energy consumption

Design

As standard, twin classifiers are manufactured in stainless steel or acid-proof steel and with shaftless spirals in black material. The lower part of the spiral is fitted with a nylon brush. Throughs are coated with Hardox wear bars or Robalon wear liners.

Technical Data

Model	Capacity (l/s)	Tank volume (m ³)	Spiral diameter (mm)	Spiral pitch, (mm)
DA 320	15	1.8	275	150
DA 420	25	4.2	375	250

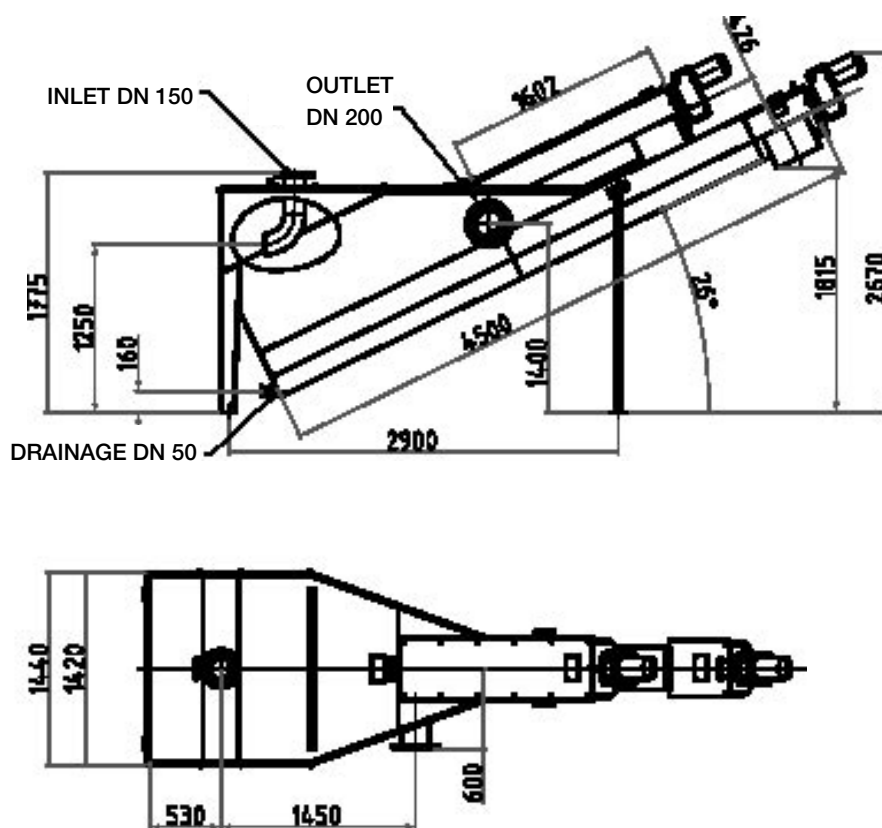

References

Läckeby Products has over 100 installations of Classifiers. The Twin Classifier is e.g. installed at Metso Panel Board, Masisa, Chile.

Läckeby Products develops, designs and manufactures classifiers. Coordinated expertise and production ensures high quality service and delivery. Läckeby Products can also participate in the planning stage and take on responsibility for everything from dimensioning to installation. Through our involvement at the planning stage, we can offer a total process guarantee.

LÄCKEBY PRODUCTS

Läckeby Mosekrogsvägen 2, SE 380 31 Läckeby, Sweden
Phone +46 480-381 00
Fax +46 480-606 63

Kungälv Bultgatan 28, SE 442 40 Kungälv, Sweden
Phone +46 303-24 64 80
Fax +46 303-928 90

www.lackebyproducts.com